



HIRED-HAND®

54 x 54 LIGHT TRAP AIR INLET

Assembly

1. The Light Trap Air Inlet consists of a galvanized steel Top, Bottom, and two Side panels which are connected together to form the Air Inlet assembly. Light Trap Extrusions are assembled in step 4, and inserted into the Air Inlet. The assembled Light Trap Air Inlet is then installed as a single unit.

The two panels having all four edges bent are the Top and Bottom. Use a tape measure and carefully measure the lengths of these two panels. The Top panel is 3/16 inch longer than the Bottom panel. The two Side panels each have two bent edges, and the Side panels are interchangeable.

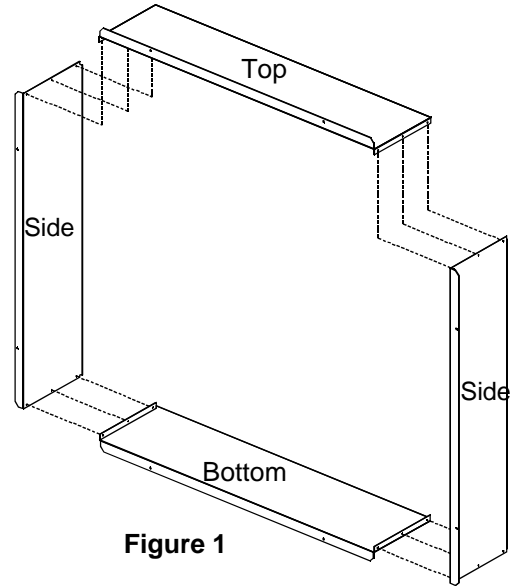

Figure 1

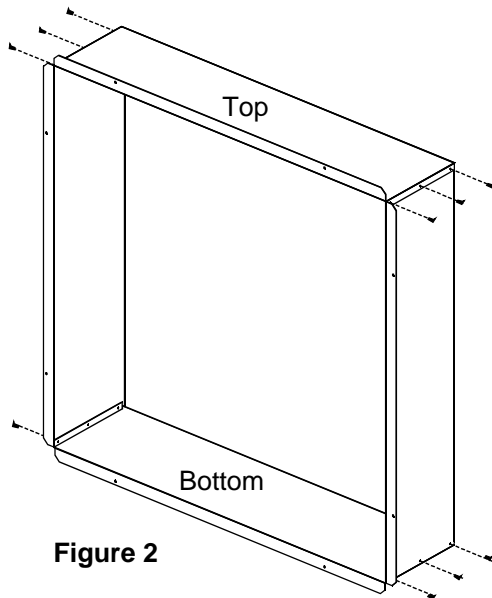

Figure 2

2. Fit the two Side panels onto the Bottom as shown in **Figure 1**. The edges of the Bottom panel fit inside the Side panels (See **Figure 1**). Connect the panels together using the 1/4 x 3/8 inch bolts provided in this kit, as shown in **Figure 2**.
3. Fit the Top panel onto the assembly as shown in **Figure 1**. The edges of the Top panel fit to the outside of the Side panels. Connect the Top to the Sides by using the 1/4 x 3/8 inch bolts (**See Figure 2**)..

4. Assemble the Light Trap Extrusions which accompany this kit according to instructions which are included with the Light Trap Extrusions. Insert the assembled Light Trap Extrusions into the Air Inlet exactly as shown in **Figure 3**.

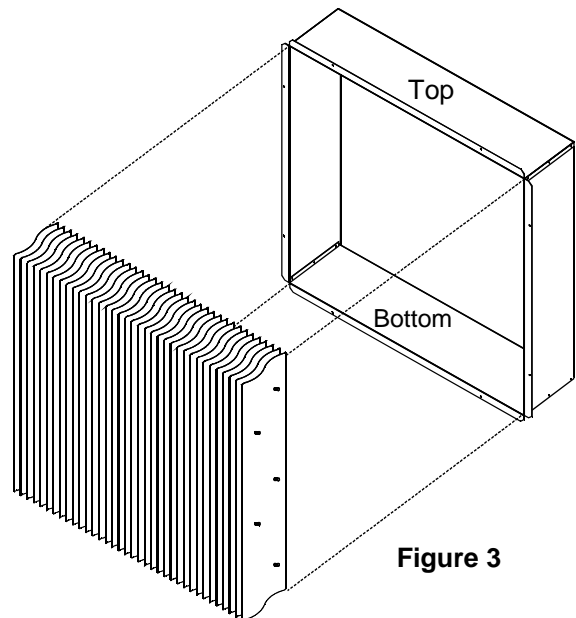

Figure 3

← *Instructions Continued On Back*

Installation

1. Cut rough opening in wall.
54 3/4" Min. x 55 3/4" Min. (See **Figure 4**).
2. Place the Light Trap Air Inlet through the opening and slide the Inlet through the opening until the flange is against the wall (**Figure 5**).
3. Secure the Light Trap Air Inlet to the wall with wood screws.
4. Installation complete.

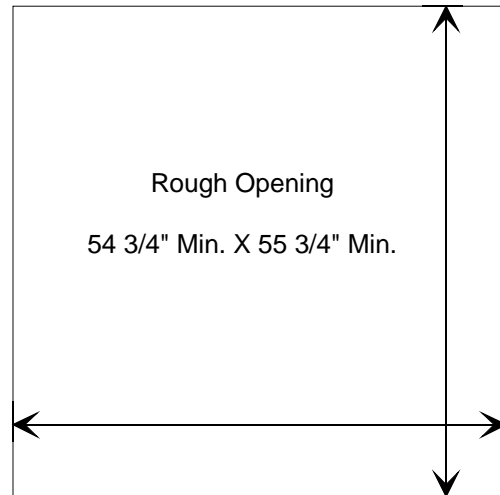

Figure 4

Other Products

Check out Hired-Hand's new Light Trap 36" and 48" fans.

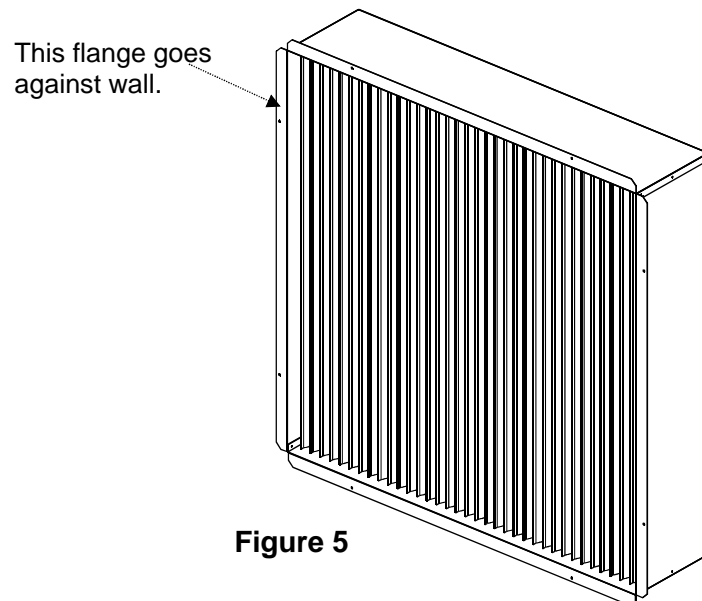

Figure 5